

REVISION			
REV.	DESCRIPTON	DATE	APPROVED
-	INITIAL RELEASE	2009/09/08	
A	零件7料號,零件9尺寸變更	2009/10/14	
B	零件7結構變更,尺寸修改	2011/11/24	

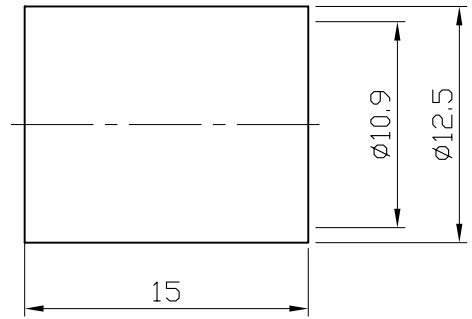
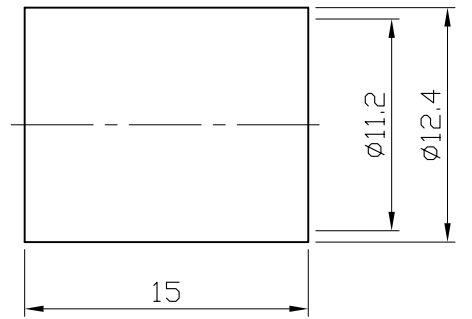
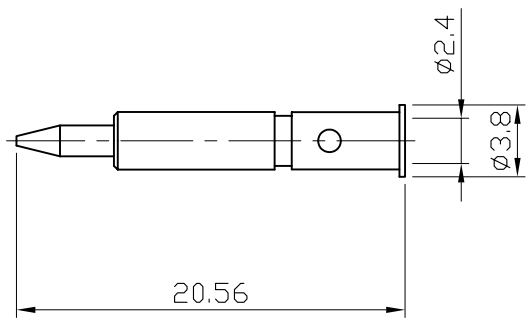
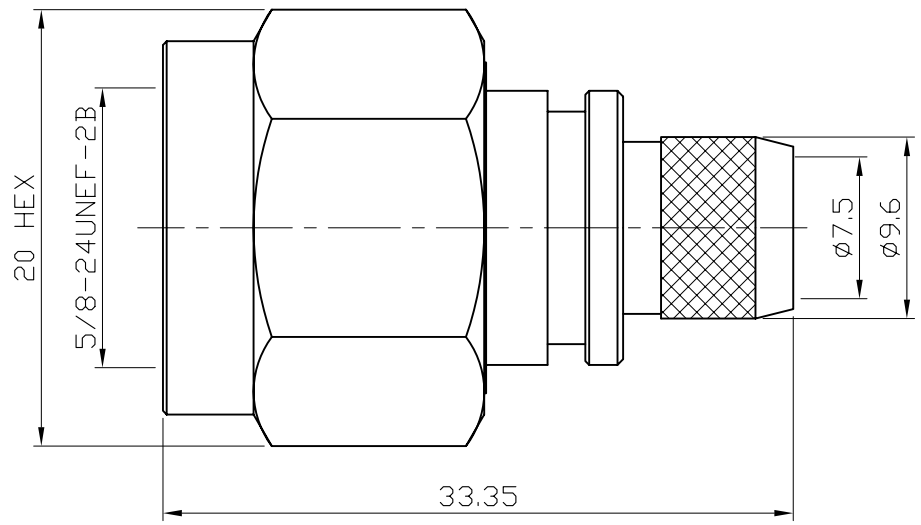

NOTES: FINISH (PLATING THICKNESS IN MICRO-INCHES)

- BRASS.
- TIN-ZINC-COPPER-ALLOY PL. 100 MIN.
OVER COPPER PL. 50 MIN.
- GOLD PL. 5 MIN. OVER NICKEL PL. 50 MIN.
OVER COPPER PL. 50 MIN.

NO.	DESCRIPTION	MATERIAL	FINISH	Q'TY	PART NO.
9	FERRULE		NOTE 1	NOTE 2	1 N3100-0213-8/W
8	FERRULE		NOTE 1	NOTE 2	1 N3100-0214-8/W
7	CONTACT PIN		NOTE 1	NOTE 3	1 N3100A-213-214-7/5G
6	RETAINER RING		NOTE 1	NOTE 2	1 N3100-6/W
5	GASKET	SILICONE			1 N3100-5
4	CONTACT BODY		NOTE 1	NOTE 2	1 N3100-4/W
3	INSULATOR	TEFLON			1 N3100-LR400-3
2	BODY		NOTE 1	NOTE 2	1 N3100-LR400-2/W
1	SHELL		NOTE 1	NOTE 2	1 N3100A-1/W

DIMENSION ARE MILLIMETERS
UNLESS OTHERWISE SPECIFIED
TOLERANCES
0.5~ 5= ±0.05
5 ~10 = ±0.07
10~20 = ±0.10
20~30 = ±0.15
30~ = ±0.20

SCALE	2.5 / 1	REV	B	UNIT	MM
APPROVED					
CHECKED					
DRAWING					
DATE					

TITLE	N PLUG CRIMP
DRAWING NO.	N3100A-0213/214

CABLE ASSEMBLY INSTRUCTION

N3100A-0213/214	DATE	2014/04/29	REV	—
-----------------	------	------------	-----	---

<p>A</p>  <p style="text-align: center;">BODY</p>	<p>B</p>  <p style="text-align: center;">CONTACT PIN</p>	<p>C</p>  <p style="text-align: center;">FERRULE</p>
--	---	---

DIAGRAM	ASSEMBLY INSTRUCTION
---------	----------------------

	<p>Step 1: STRIP AS SHOWN.</p>
--	--------------------------------

	<p>Step 2: SLIDE FERRULE " C " OVER CABLE. Step 3: PUT PIN " B " ON CENTER CONDUCTOR AND SOLDER IN " Y ".</p>
---	---

	<p>Step 4: LOOSEN BRAIDING AND SLIDE CONNECTOR " A " IN PLACE.</p>
---	--

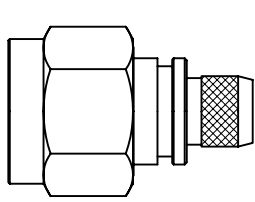
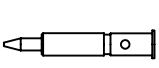
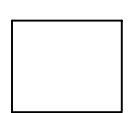
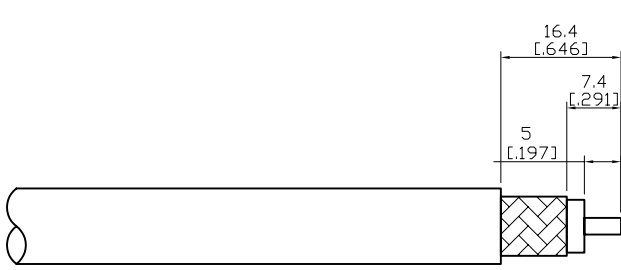
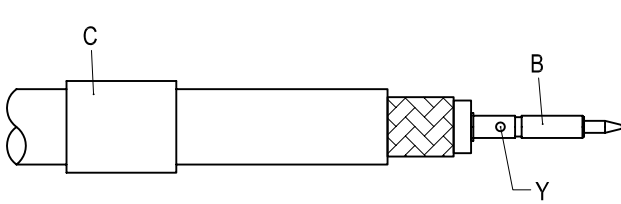
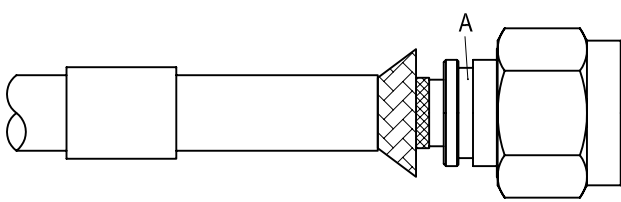
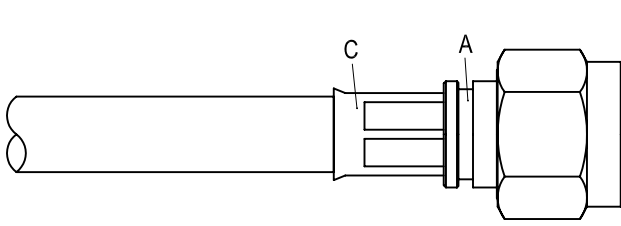
	<p>Step 5: SLIDE FERRULE " C " TOWARDS THE CONNECTOR " A " AND CRIMP. (USE 10.7mm/0.421inch HEX SECTION OF INSERT-C)</p>
---	--

This part number complies with RoHS.

APPROVED	CHECKED	DRAWING
----------	---------	---------

Albert