

400BPDM-C

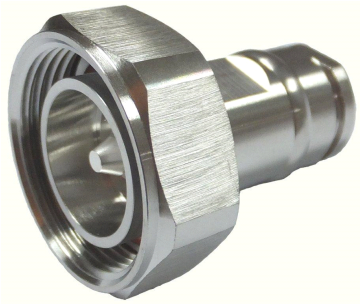

7-16 DIN Male for CNT-400 braided cable

Product Classification

Brand	CNT®
Product Type	Braided cable connector

General Specifications

Interface	7-16 DIN Male
Body Style	Straight

Electrical Specifications

Operating Frequency Band	0 – 6000 MHz
Average Power at Frequency	580.0 W @ 900 MHz
Cable Impedance	50 ohm
Connector Impedance	50 ohm
RF Operating Voltage, maximum (vrms)	894.00 V
dc Test Voltage	2500 V
Outer Contact Resistance, maximum	0.40 mOhm
Inner Contact Resistance, maximum	1.50 mOhm
Insulation Resistance, minimum	10000 MOhm
Insertion Loss, typical	0.05 dB

400BPDM-C

Outline Drawing

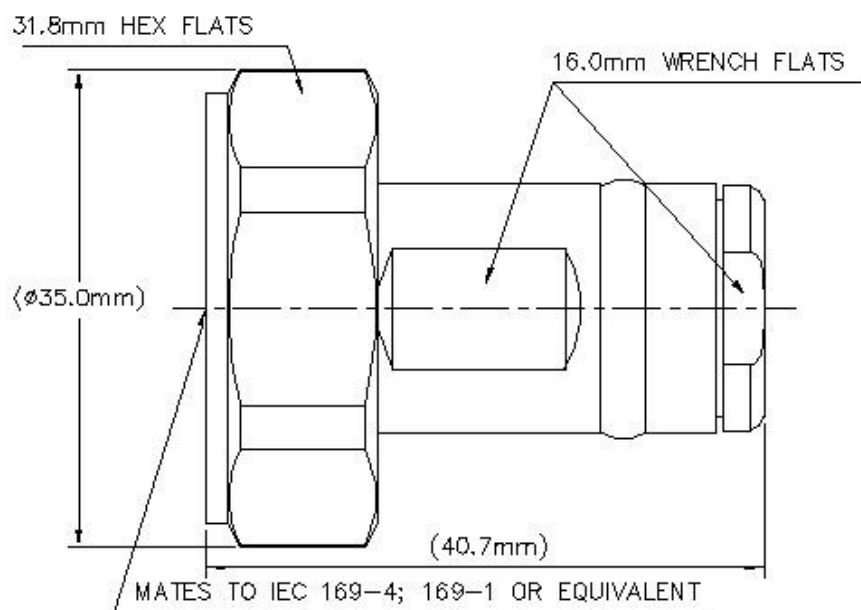

Mechanical Specifications

Outer Contact Attachment Method	Clamp
Outer Contact Plating	Trimetal
Inner Contact Plating	Silver
Inner Contact Attachment Method	Captivated
Interface Durability	500 cycles
Interface Durability Method	IEC 61169-4:17
Connector Retention Tensile Force	330 N 74 lbf
Connector Retention Torque	0.56 N-m 0.41 ft lb
Coupling Nut Proof Torque	35.00 N-m 25.81 ft lb
Coupling Nut Proof Torque Method	IEC 61169-4:9.3.6
Coupling Nut Retention Force	1000.00 N 224.81 lbf
Coupling Nut Retention Force Method	IEC 61169-4:15.2.6

Dimensions

Nominal Size	0.405 in
Diameter	35.00 mm 1.38 in
Length	40.73 mm 1.60 in
Weight	44.58 g 0.10 lb

400BPDM-C

Width 35.00 mm | 1.38 in

Environmental Specifications

Operating Temperature	-40 °C to +85 °C (-40 °F to +185 °F)
Storage Temperature	-65 °C to +125 °C (-85 °F to +257 °F)
Immersion Depth	1 m
Immersion Test Mating	Mated
Immersion Test Method	IEC 60529:2001, IP68
Mechanical Shock Test Method	IEC 60068-2-27
Climatic Sequence Test Method	IEC 60068-1
Damp Heat Steady State Test Method	IEC 60068-2-3
Thermal Shock Test Method	IEC 60068-2-14
Vibration Test Method	IEC 60068-2-6
Corrosion Test Method	IEC 60068-2-11

Standard Conditions

Attenuation, Ambient Temperature	20 °C 68 °F
Average Power, Ambient Temperature	40 °C 104 °F
Average Power, Inner Conductor Temperature	100 °C 212 °F

Return Loss/VSWR

Frequency Band	VSWR	Return Loss (dB)
0–3000 MHz	1.05	32.26
3000–6000 MHz	1.12	25.00

Regulatory Compliance/Certifications

Agency	Classification
RoHS 2011/65/EU	Compliant by Exemption
ISO 9001:2015	Designed, manufactured and/or distributed under this quality management system
China RoHS SJ/T 11364-2014	Above Maximum Concentration Value (MCV)



* Footnotes

Immersion Depth	Immersion at specified depth for 24 hours
Insertion Loss, typical	$0.05\sqrt{\text{freq (GHz)}}$ (not applicable for elliptical waveguide)