

# 400BPNF-C

---



Type N Female for CNT-400 braided cable

## Product Classification

<b>Brand</b>	CNT®   ConQuest®
<b>Product Type</b>	Braided cable connector

## General Specifications

<b>Interface</b>	N Female
<b>Body Style</b>	Straight

## Electrical Specifications

<b>Operating Frequency Band</b>	0 – 6000 MHz
<b>Cable Impedance</b>	50 ohm
<b>Connector Impedance</b>	50 ohm
<b>RF Operating Voltage, maximum (vrms)</b>	707.00 V
<b>dc Test Voltage</b>	2500 V
<b>Outer Contact Resistance, maximum</b>	0.25 mOhm
<b>Inner Contact Resistance, maximum</b>	1.00 mOhm
<b>Insulation Resistance, minimum</b>	5000 MOhm
<b>Insertion Loss, typical</b>	0.05 dB

# 400BPNF-C

## Outline Drawing

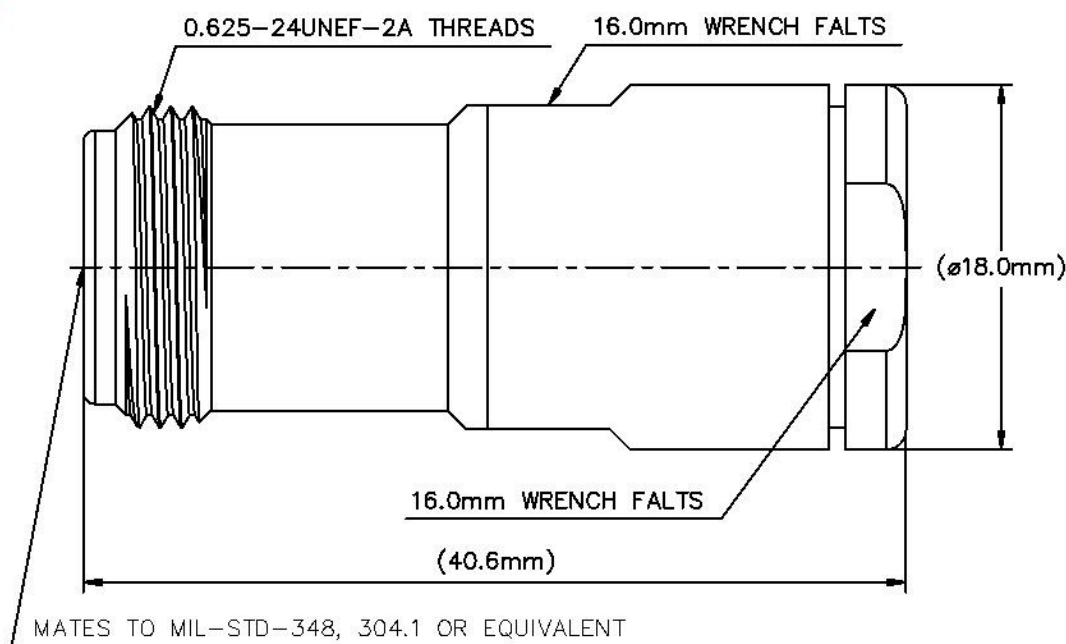

## Mechanical Specifications

<b>Outer Contact Attachment Method</b>	Clamp
<b>Outer Contact Plating</b>	Trimetal
<b>Inner Contact Plating</b>	Silver
<b>Inner Contact Attachment Method</b>	Captivated
<b>Interface Durability</b>	500 cycles
<b>Interface Durability Method</b>	IEC 61169-16:9.5
<b>Connector Retention Tensile Force</b>	330 N   74 lbf
<b>Connector Retention Torque</b>	0.56 N-m   0.41 ft lb

## Dimensions

<b>Nominal Size</b>	0.405 in
<b>Diameter</b>	18.00 mm   0.71 in
<b>Length</b>	40.55 mm   1.60 in
<b>Weight</b>	44.58 g   0.10 lb
<b>Width</b>	18.00 mm   0.71 in

## Environmental Specifications

# 400BPNF-C

---

<b>Operating Temperature</b>	-40 °C to +85 °C (-40 °F to +185 °F)
<b>Storage Temperature</b>	-65 °C to +125 °C (-85 °F to +257 °F)
<b>Immersion Depth</b>	1 m
<b>Immersion Test Mating</b>	Mated
<b>Immersion Test Method</b>	IEC 60529:2001, IP68
<b>Mechanical Shock Test Method</b>	IEC 60068-2-27
<b>Climatic Sequence Test Method</b>	IEC 60068-1
<b>Damp Heat Steady State Test Method</b>	IEC 60068-2-3
<b>Thermal Shock Test Method</b>	IEC 60068-2-14
<b>Vibration Test Method</b>	IEC 60068-2-6
<b>Corrosion Test Method</b>	IEC 60068-2-11

## Standard Conditions

<b>Attenuation, Ambient Temperature</b>	20 °C   68 °F
<b>Average Power, Ambient Temperature</b>	40 °C   104 °F
<b>Average Power, Inner Conductor Temperature</b>	100 °C   212 °F

## Return Loss/VSWR

<b>Frequency Band</b>	<b>VSWR</b>	<b>Return Loss (dB)</b>
0–3000 MHz	1.05	32.26
3000–6000 MHz	1.12	24.94

## Regulatory Compliance/Certifications

<b>Agency</b>	<b>Classification</b>
RoHS 2011/65/EU	Compliant by Exemption
ISO 9001:2015	Designed, manufactured and/or distributed under this quality management system
China RoHS SJ/T 11364-2014	Above Maximum Concentration Value (MCV)



## \* Footnotes

<b>Immersion Depth</b>	Immersion at specified depth for 24 hours
<b>Insertion Loss, typical</b>	0.05√freq (GHz) (not applicable for elliptical waveguide)