

# L4TDM-PSA

---



7-16 DIN Male Positive Stop™ for 1/2 in AL4RPV-50, LDF4-50A, HL4RPV-50 cable

## Product Classification

**Brand** HELIAX® | Positive Stop™  
**Product Type** Wireless and radiating connector

## General Specifications

**Interface** 7-16 DIN Male  
**Body Style** Straight  
**Harmonized System (HS) Code** 854420 (Coaxial cable and other coaxial electric conductors)  
**Mounting Angle** Straight  
**Ordering Note** CommScope® standard product (Global)

## Electrical Specifications

**Connector Impedance** 50 ohm  
**Operating Frequency Band** 0 – 8800 MHz  
**Average Power at Frequency** 1.1 kW @ 900 MHz  
**Cable Impedance** 50 ohm  
**3rd Order IMD, typical** -120 dBm @ 910 MHz  
**3rd Order IMD Test Method** Two +43 dBm carriers  
**RF Operating Voltage, maximum (vrms)** 1415.00 V  
**dc Test Voltage** 4000 V  
**Outer Contact Resistance, maximum** 1.50 mOhm  
**Inner Contact Resistance, maximum** 0.80 mOhm  
**Insulation Resistance, minimum** 5000 MOhm  
**Peak Power, maximum** 40.00 kW  
**Insertion Loss, typical** 0.05 dB  
**Shielding Effectiveness** -110 dB

## Outline Drawing

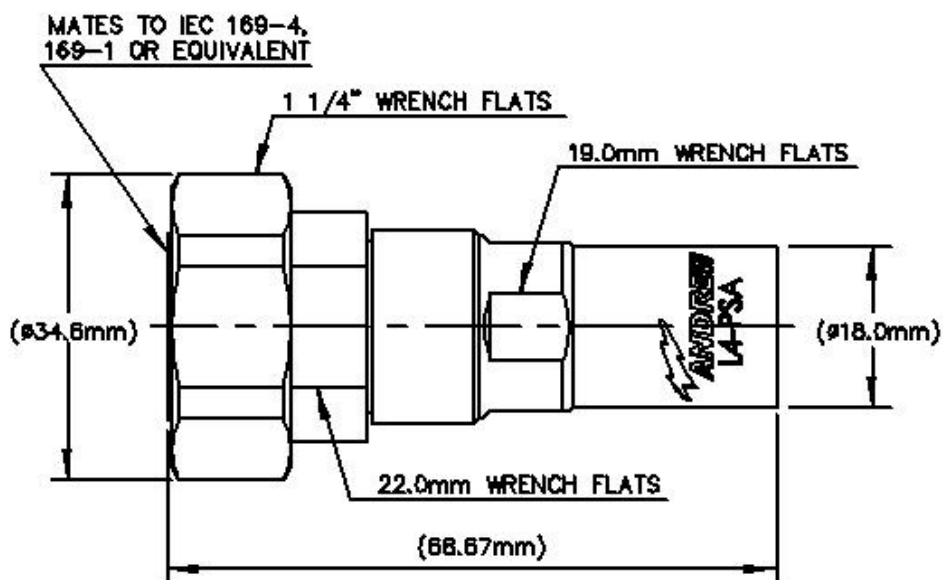

## Mechanical Specifications

<b>Outer Contact Attachment Method</b>	Ring-flare
<b>Inner Contact Attachment Method</b>	Captivated
<b>Outer Contact Plating</b>	Trimetal
<b>Inner Contact Plating</b>	Silver
<b>Attachment Durability</b>	25 cycles
<b>Interface Durability</b>	500 cycles
<b>Interface Durability Method</b>	IEC 61169-4:9.5
<b>Connector Retention Tensile Force</b>	890 N   200 lbf
<b>Connector Retention Torque</b>	5.42 N-m   48.00 in lb
<b>Insertion Force</b>	200.17 N   45.00 lbf
<b>Insertion Force Method</b>	IEC 61169-1:15.2.4
<b>Coupling Nut Proof Torque</b>	25.00 N-m   221.27 in lb
<b>Coupling Nut Retention Force</b>	1000.00 N   224.81 lbf
<b>Coupling Nut Retention Force Method</b>	MIL-C-39012C-3.25, 4.6.22

## Dimensions

<b>Nominal Size</b>	1/2 in
<b>Diameter</b>	34.60 mm   1.36 in

# L4TDM-PSA

<b>Length</b>	68.67 mm   2.70 in
<b>Weight</b>	120.09 g   0.26 lb

## Environmental Specifications

<b>Operating Temperature</b>	-55 °C to +85 °C (-67 °F to +185 °F)
<b>Storage Temperature</b>	-55 °C to +85 °C (-67 °F to +185 °F)
<b>Immersion Depth</b>	1 m
<b>Immersion Test Mating</b>	Unmated
<b>Immersion Test Method</b>	IEC 60529:2001, IP68
<b>Water Jetting Test Mating</b>	Unmated
<b>Water Jetting Test Method</b>	IEC 60529:2001, IP66
<b>Moisture Resistance Test Method</b>	MIL-STD-202F, Method 106F
<b>Mechanical Shock Test Method</b>	MIL-STD-202, Method 213, Test Condition I
<b>Thermal Shock Test Method</b>	MIL-STD-202F, Method 107G, Test Condition A-1, Low Temperature -55 °C
<b>Vibration Test Method</b>	IEC 60068-2-6
<b>Corrosion Test Method</b>	MIL-STD-1344A, Method 1001.1, Test Condition A

## Return Loss/VSWR

<b>Frequency Band</b>	<b>VSWR</b>	<b>Return Loss (dB)</b>
45–1000 MHz	1.02	39.00
1010–2200 MHz	1.03	37.00
2200–3000 MHz	1.05	33.00
3010–4000 MHz	1.07	29.00
4010–6000 MHz	1.11	26.00
6010–8000 MHz	1.15	23.00

## Regulatory Compliance/Certifications

<b>Agency</b>	<b>Classification</b>
RoHS 2011/65/EU	Compliant by Exemption
ISO 9001:2015	Designed, manufactured and/or distributed under this quality management system
China RoHS SJ/T 11364-2014	Above Maximum Concentration Value (MCV)



## \* Footnotes

<b>Immersion Depth</b>	Immersion at specified depth for 24 hours
<b>Insertion Loss, typical</b>	$0.05\sqrt{f}$ /freq (GHz) (not applicable for elliptical waveguide)