

L4TNM-PSA



Type N Male Positive Stop™ for 1/2 in AL4RPV-50, LDF4-50A, HL4RPV-50 cable

- This product is part of the CommScope Wired for Wireless® Solution

Product Classification

Brand	HELIAX® Positive Stop™
Product Type	Wireless and radiating connector

General Specifications

Interface	N Male
Body Style	Straight
Harmonized System (HS) Code	854420 (Coaxial cable and other coaxial electric conductors)
Mounting Angle	Straight
Ordering Note	CommScope® standard product (Global)

Electrical Specifications

Connector Impedance	50 ohm
Operating Frequency Band	0 – 8800 MHz
Average Power at Frequency	0.6 kW @ 900 MHz
Cable Impedance	50 ohm
3rd Order IMD, typical	-116 dBm @ 910 MHz
3rd Order IMD Test Method	Two +43 dBm carriers
RF Operating Voltage, maximum (vrms)	707.00 V
dc Test Voltage	2000 V
Outer Contact Resistance, maximum	0.30 mOhm
Inner Contact Resistance, maximum	2.00 mOhm
Insulation Resistance, minimum	5000 MOhm
Peak Power, maximum	10.00 kW
Insertion Loss, typical	0.05 dB
Shielding Effectiveness	-130 dB

L4TNM-PSA

Outline Drawing

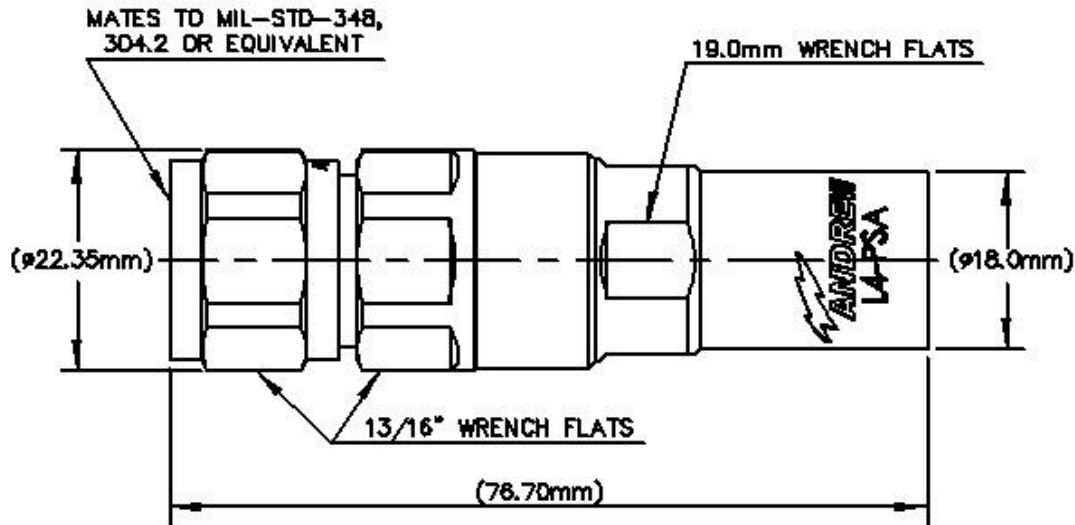

Mechanical Specifications

Outer Contact Attachment Method	Ring-flare
Inner Contact Attachment Method	Captivated
Outer Contact Plating	Trimetal
Inner Contact Plating	Silver
Attachment Durability	25 cycles
Interface Durability	500 cycles
Interface Durability Method	IEC 61169-16:9.5
Connector Retention Tensile Force	890 N 200 lbf
Connector Retention Torque	5.42 N-m 48.00 in lb
Insertion Force	66.72 N 15.00 lbf
Insertion Force Method	MIL-C-39012C-3.12, 4.6.9
Coupling Nut Proof Torque	4.52 N-m 40.00 in lb
Coupling Nut Retention Force	444.82 N 100.00 lbf
Coupling Nut Retention Force Method	MIL-C-39012C-3.25, 4.6.22

Dimensions

Nominal Size	1/2 in
Diameter	22.35 mm 0.88 in

L4TNM-PSA

Length	76.70 mm 3.02 in
Weight	94.71 g 0.21 lb

Environmental Specifications

Operating Temperature	-55 °C to +85 °C (-67 °F to +185 °F)
Storage Temperature	-55 °C to +85 °C (-67 °F to +185 °F)
Immersion Depth	1 m
Immersion Test Mating	Unmated
Immersion Test Method	IEC 60529:2001, IP68
Water Jetting Test Mating	Unmated
Water Jetting Test Method	IEC 60529:2001, IP66
Moisture Resistance Test Method	MIL-STD-202F, Method 106F
Mechanical Shock Test Method	MIL-STD-202, Method 213, Test Condition I
Thermal Shock Test Method	MIL-STD-202F, Method 107G, Test Condition A-1, Low Temperature -55 °C
Vibration Test Method	IEC 60068-2-6
Corrosion Test Method	MIL-STD-1344A, Method 1001.1, Test Condition A

Return Loss/VSWR

Frequency Band	VSWR	Return Loss (dB)
45–1000 MHz	1.02	39.00
1010–2200 MHz	1.03	37.00
2210–3000 MHz	1.05	33.00
3010–4000 MHz	1.09	27.00
4010–6000 MHz	1.25	19.00
6010–8000 MHz	1.33	17.00

Regulatory Compliance/Certifications

Agency	Classification
RoHS 2011/65/EU	Compliant by Exemption
ISO 9001:2015	Designed, manufactured and/or distributed under this quality management system
China RoHS SJ/T 11364-2014	Above Maximum Concentration Value (MCV)



* Footnotes

Immersion Depth	Immersion at specified depth for 24 hours
Insertion Loss, typical	$0.05\sqrt{f}$ /freq (GHz) (not applicable for elliptical waveguide)