

F4PNF-C



Type N Female for 1/2 in FSJ4-50B cable

Product Classification

Brand	HELIAX®
Product Type	Wireless and radiating connector

General Specifications

Interface	N Female
Body Style	Straight
Mounting Angle	Straight
Ordering Note	CommScope® standard product (Global)

Electrical Specifications

Connector Impedance	50 ohm
Operating Frequency Band	0 – 12000 MHz
Average Power at Frequency	0.6 kW @ 900 MHz
Cable Impedance	50 ohm
3rd Order IMD, typical	-120 dBm @ 910 MHz
3rd Order IMD Test Method	Two +43 dBm carriers
RF Operating Voltage, maximum (vrms)	707.00 V
dc Test Voltage	2000 V
Outer Contact Resistance, maximum	0.30 mOhm
Inner Contact Resistance, maximum	2.00 mOhm
Insulation Resistance, minimum	5000 MOhm
Peak Power, maximum	10.00 kW
Insertion Loss, typical	0.05 dB
Shielding Effectiveness	-110 dB

F4PNF-C

Outline Drawing

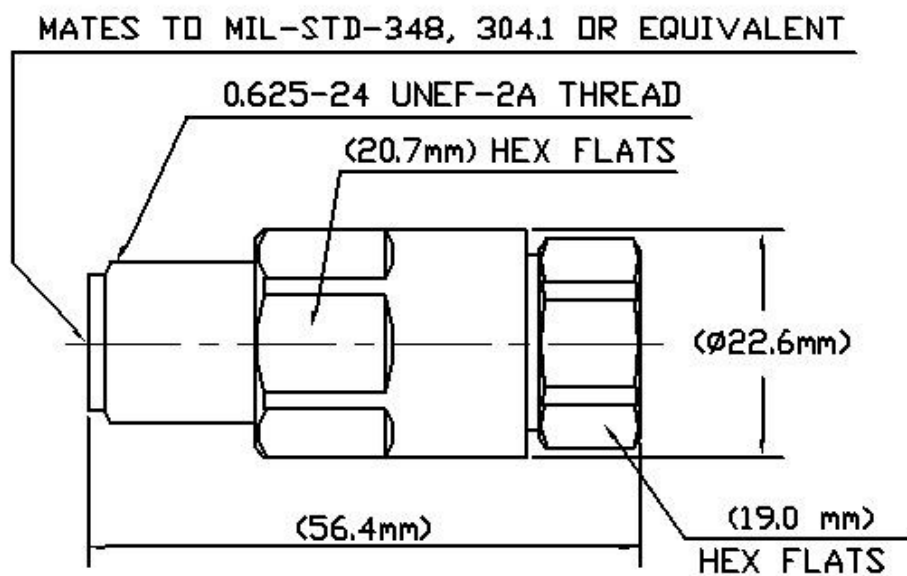

Mechanical Specifications

Outer Contact Attachment Method	Self-flare
Inner Contact Attachment Method	Captivated
Outer Contact Plating	Trimetal
Inner Contact Plating	Gold
Attachment Durability	25 cycles
Interface Durability	500 cycles
Interface Durability Method	IEC 61169-16:9.5
Connector Retention Tensile Force	890 N 200 lbf
Connector Retention Torque	5.42 N-m 48.00 in lb
Insertion Force	66.72 N 15.00 lbf
Insertion Force Method	MIL-C-39012C-3.12, 4.6.9
Pressurizable	No

Dimensions

Nominal Size	1/2 in
Diameter	22.00 mm 0.87 in
Length	53.01 mm 2.09 in
Weight	95.26 g 0.21 lb

Environmental Specifications

Operating Temperature	-55 °C to +85 °C (-67 °F to +185 °F)
Storage Temperature	-55 °C to +85 °C (-67 °F to +185 °F)
Immersion Depth	1 m
Immersion Test Mating	Mated
Immersion Test Method	IEC 60529:2001, IP68
Water Jetting Test Mating	Mated
Water Jetting Test Method	IEC 60529:2001, IP66
Moisture Resistance Test Method	MIL-STD-202F, Method 106F
Mechanical Shock Test Method	MIL-STD-202F, Method 213B, Test Condition C
Thermal Shock Test Method	MIL-STD-202, Method 107, Test Condition A-1, Low Temperature -55 °C
Vibration Test Method	MIL-STD-202F, Method 204D, Test Condition B
Corrosion Test Method	MIL-STD-1344A, Method 1001.1, Test Condition A

Standard Conditions

Attenuation, Ambient Temperature	20 °C 68 °F
Average Power, Ambient Temperature	40 °C 104 °F

Return Loss/VSWR

Frequency Band	VSWR	Return Loss (dB)
0–1000 MHz	1.03	36.00
1000–2300 MHz	1.05	32.00
2300–3000 MHz	1.07	29.00
3000–4000 MHz	1.17	22.00
4000–8000 MHz	1.38	16.00
8000–10200 MHz	1.5	14.00

Regulatory Compliance/Certifications

Agency	Classification
RoHS 2011/65/EU	Compliant by Exemption
ISO 9001:2015	Designed, manufactured and/or distributed under this quality management system
China RoHS SJ/T 11364-2014	Above Maximum Concentration Value (MCV)



* Footnotes

Immersion Depth Immersion at specified depth for 24 hours

F4PNF-C

Insertion Loss, typical $0.05\sqrt{f_{\text{req}}}$ (GHz) (not applicable for elliptical waveguide)