

N8105-0213

N Jack Crimp For Bulkhead

50Ω

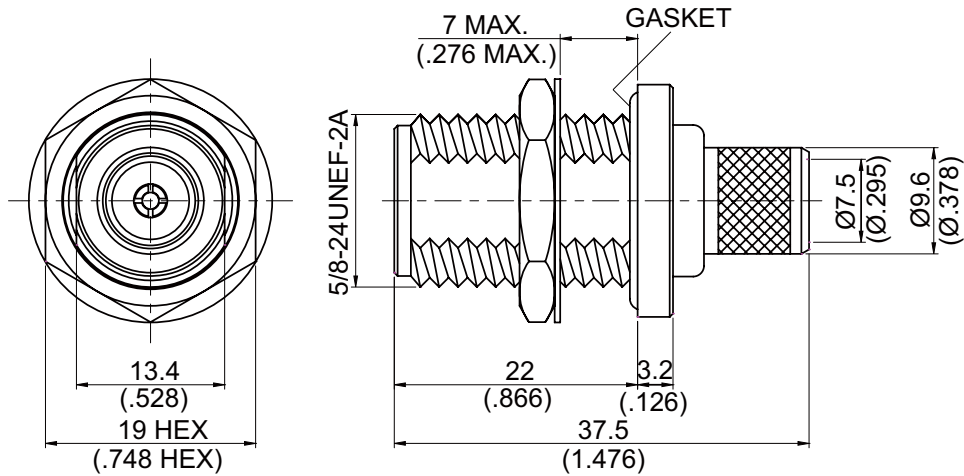

MOUNTING HOLE :

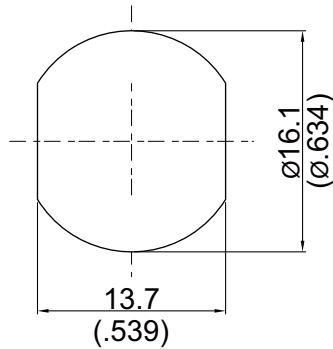

Parts	Material	Plating (Micro-inch)
Hex Nut	Brass	Tin-Zinc-Copper-Alloy 100 Over Copper 50
Lock Washer	Brass	Tin-Zinc-Copper-Alloy 100 Over Copper 50
Gasket	Silicon	
Ferrule	Brass	Tin-Zinc-Copper-Alloy 100 Over Copper 50
Contact Pin	Phosphor Bronze	Gold 4 Over Nickel-Phosphorus 80 Over Copper 20
Barrel	Brass	Tin-Zinc-Copper-Alloy 100 Over Copper 50
Insulator	Teflon	
Body	Brass	Tin-Zinc-Copper-Alloy 100 Over Copper 50

Weight:
Suitable Cables:RG213

This part number complies with RoHS.

CABLE ASSEMBLY INSTRUCTION

N8105-0213

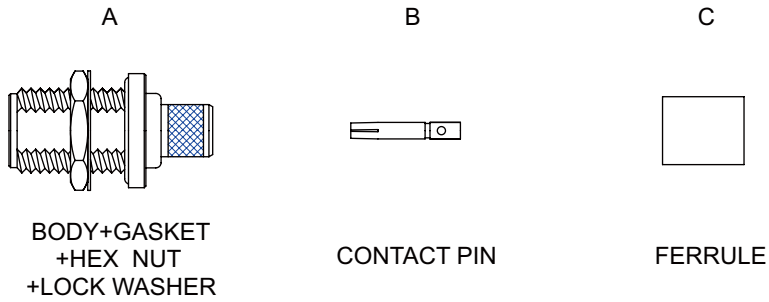
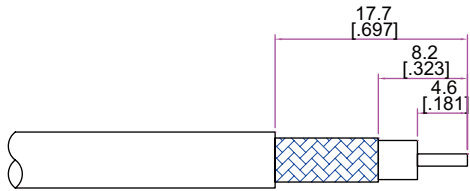
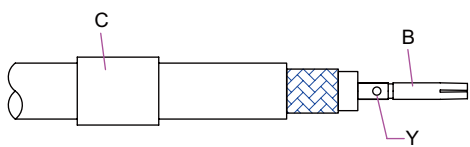
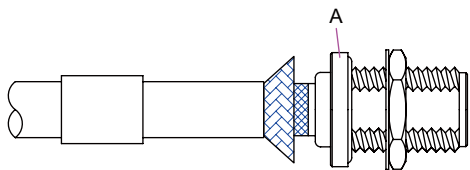
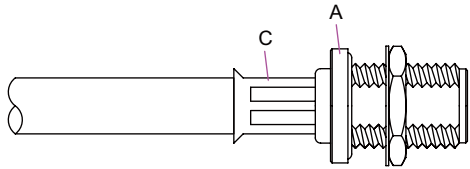

DIAGRAM	ASSEMBLY INSTRUCTION
	<p>Step 1: STRIP AS SHOWN .</p>
	<p>Step 2: SLIDE FERRULE " C " OVER CABLE. Step 3: PUT PIN " B " ON CENTER CONDUCTOR AND SOLDER IN " Y " .</p>
	<p>Step 4: LOOSEN BRAIDING AND SLIDE CONNECTOR " A " IN PLACE.</p>
	<p>Step 5: SLIDE FERRULE " C " TOWARDS THE CONNECTOR " A " AND CRIMP.</p>

This part number complies with RoHS.